



Pressing for Excellence

A photograph of a silver or light-colored luxury car, possibly a sedan, captured in motion. The car is shown from a side-rear perspective, moving towards the right. The background is blurred, suggesting speed. A large, semi-transparent blue overlay covers the left side of the image, and a dark blue horizontal bar is positioned at the bottom, containing the text.

Interior Finishing and Laminating

Table of Contents

Interior Finishing

VEIT SG 67 Steam Generator	4
VEIT 2157 Hand Finisher	7
VEIT 2218 Steam Reheater	7
VEIT IF 60 Interior Finisher	8

Laminating Machines

Laminating Machine Portfolio	10
Laminating Machine LM	12
AX 450 / 450 C	20
BX 600 / 1000	22
BH 600	25

Technical Data	26
----------------------	----



Interior Finishing



SG 67 Steam Generator

Taking SteamGenerators to the next level

Adjustable steam quality

Select dry or moist steam for processing different types of products

Direct water connection without additional container (on request) automatic refilling, no additional space needed

Easy access for maintenance and servicing.

Longer operating hours without refilling enlarged container capacity

Stainless steel boiler

for applications with special hygiene requirements

Integrated locking castors for flexible mobility on site



Three performance levels

with steam capacities from 3 to 9 kg per hour

2.2 kW – 230 V for 3.0 kg steam/h, one connection, e. g. for one iron

4.4 kW – 400 V for 6.0 kg steam/h, two connections, e. g. for two irons

6.6 kW – 400 V for 9.0 kg steam/h, two connections, e. g. for two AS-irons, very short heating time

All these versions are also available with a ball valve which can be used with all-steam irons or other steam units.

With distilled and osmosis water possible with a conductivity of at least 5 $\mu\text{S}/\text{cm}$.

Automatic cleaning system with VEIT

SteamClean (only possible in combination with

the SG67 4.4 kW C)

keeps the unit clean and extends the components' lifespan

Versatile connections

for up to two workplaces, steam reheaters and spotting tables

Integrated iron connections

for safe and comfortable connection of up to two units

Safe automatic filling

avoids running dry and thus makes venting redundant

Top facing valve for blow-down

more ergonomic user friendliness with bigger distance to hot steam

Operation with distilled water* and reverse osmosis water possible

no blow down required in this case

Small dimensions

more power on less space

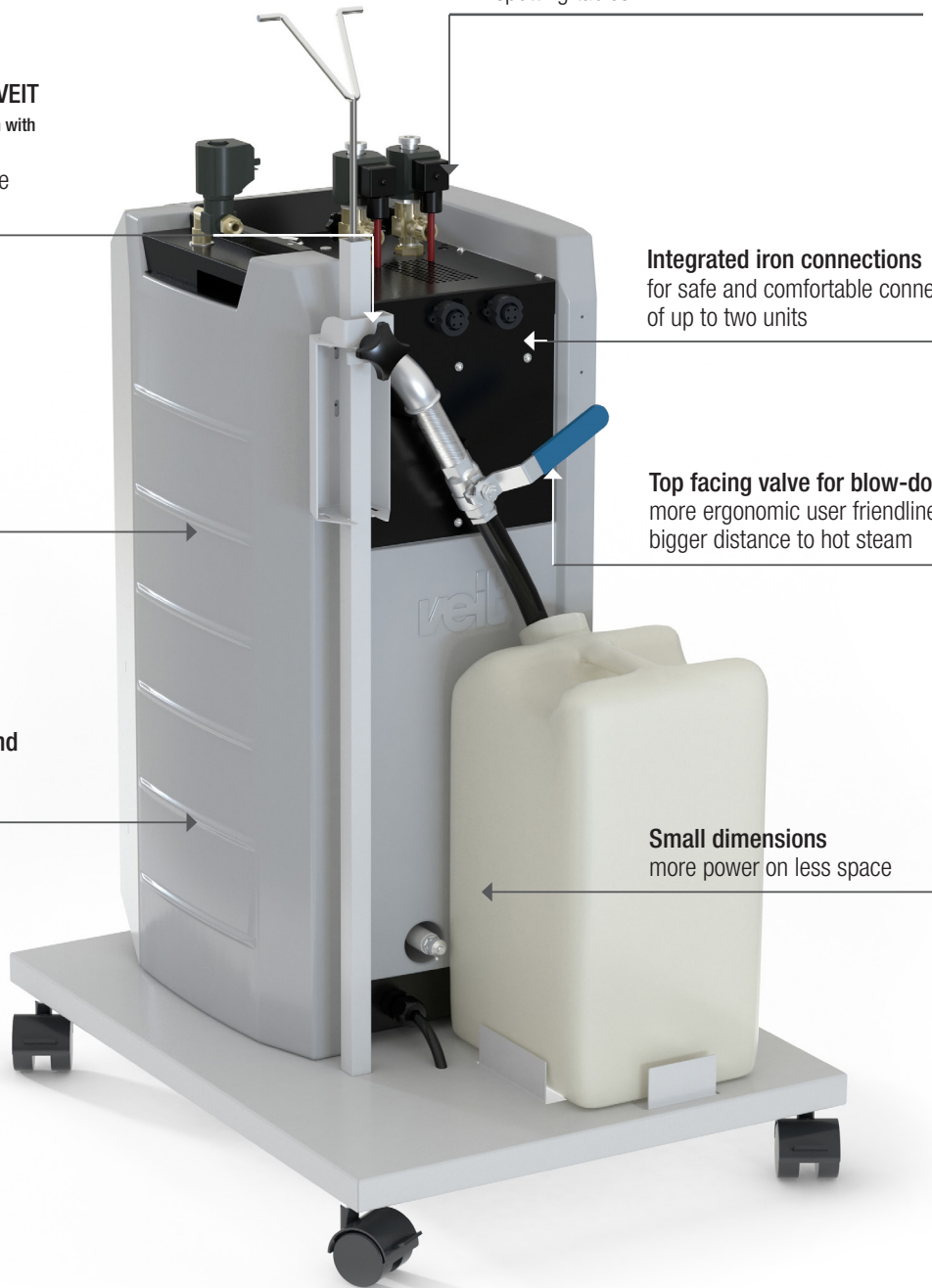

VEIT **eMotion** in SG 67

Our holistic **eMotion** approach was very much in the focus when developing our new machine generation. Your production will sustainably benefit from the economic use of resources::

- > Energy savings through pre-heated feedwater
- > Reduced air-conditioning costs thanks to extremely low heat radiation of machine
- > The reduced heat radiation creates a pleasant work environment with satisfied employees and little absenteeism

*Full functionality is guaranteed from a conductivity of 2.5 $\mu\text{S}/\text{cm}$. With 1.5 - 2.5 $\mu\text{S}/\text{cm}$ limited operation if necessary. Under 1.5 $\mu\text{S}/\text{cm}$ there is no guarantee of functionality.

When Flexibility meets Perfection ...

With their high-quality workmanship, VEIT steam generators are suitable for **non-stop operation in a very wide range of industrial applications:**



Garment and textiles industry



Automotive industry



Chemical industry, production & laboratories



Hospitals and pharmacies



Food and beverage sector



Packaging sector



Iron and steel industry



When Simplicity meets Quality ...

Any ancillary equipment available by VEIT **can be fully integrated** to create a customized work place around your steam generator. This includes a steam reheater, the Detaset spotting unit, hose and cable supports and a holder for the hand finisher

When Innovation meets Functionality ...

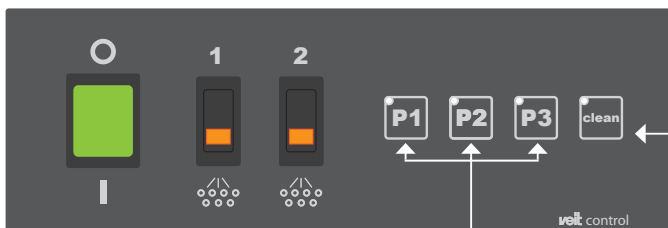

The VEIT Control Unit provides a choice between three power levels. By selecting **more or less humid steam** for different product groups, customized settings are perfectly easy to implement.*

In combination with the SteamClean cleaning agent, the **automatic cleaning cycle** replaces the daily blow-down procedure and protects the boiler against calcification and corrosion for a long time.*

... it is „Taking SteamGenerators to the next level“



VEIT 2157 Hand Finisher

For manual finishing of fabric or leather-covered interior parts and for removing creases, shine and marks on interior surfaces. The teflon frame sole attachment is used for smoothing or improving the shape of uneven surfaces, whereas the steam brush attachment gives an excellent appearance to leather, velours or delicate fabrics.

- > Weight: 620 g / 1.37 lbs
- > 100–240V; 500W; 50–60Hz
- > ironing surface: 125 × 85 mm / 4.92 × 3.35 inch

VEIT 2157 Hand Finisher with Ironing Egg

For manual finishing of outlines, impressions and curves of all kinds of fabric and leather covered interior components. Due to the ergonomic design and precision shape of the Hand Finisher, it is possible to finish all kinds of outlines, impressions and curves.

- > Weight 900 g / 1.98 lbs
- > 100–240V; 500W; 50–60Hz
- > ironing surface: 125 × 85 mm / 4.92 × 3.35 inch



Teflon Frame Sole and Brush

For VEIT Hand Finisher 2157

Standard equipment includes layers of Aerofit and stainless steel to provide micro fine steam. The teflon frame sole removes creases without shine-marks on flat materials. The brush is used for napped and sensitive fabrics.

- > Brush hard
- > Brush soft
- > Brush Premium
- > Teflon frame sole
- > Teflon frame sole premium
- > Full teflon frame sole

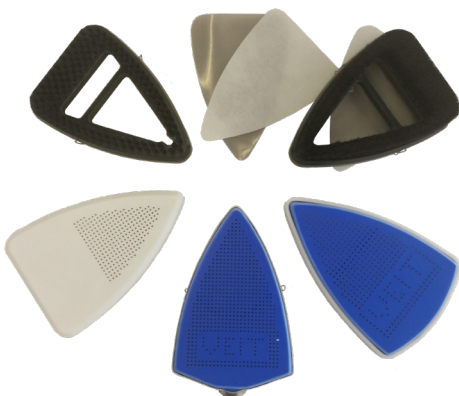

Holder Handfinisher

Together with a **VEIT steam generator**, this is the ideal combination as a support for the **VEIT 2216 Steam Reheater** and as a rest for the VEIT 2157 Hand Finisher.

VEIT 2218 Steam Reheater

Working with a mobile VEIT steam generator, the **VEIT 2218 Steam Reheater** provides a high quality condensate-free steam for the **VEIT 2157 Hand Finisher**.





VEIT IF 60 Interior Finisher

The **VEIT IF 60 Interior Finisher** is suitable for all interior parts. It provides a consistent, excellent quality finish for all types of fabrics and leather-covered surfaces.

Marks are removed – including indentions or pressure marks on back-sprayed injection-molded parts as well as on cushioned products – thanks to the combination of VEIT's tried and tested steam spraying with a temperature-controlled airflow..

Flexible

The **VEIT IF 60 Interior Finisher** can be set up as an independent operation or incorporated into an existing production line. Depending on the flow of goods and type of parts, the machine can be set to manual or automatic operation.

The Interior Finisher is available with following working widths:
 > 1000 mm > 1600 mm

The VEIT IF 60 Interior Finisher consists of four units: Loading and Unloading Station

The parts are loaded manually or automatically across the entire width of the conveyor belt for treatment in the steam unit. Optionally, loading can be performed by a preceding conveyor belt. The finished parts can be unloaded manually or automatically. If the finisher is incorporated into an existing production line, no unloading station is required.

Steam Unit

The parts are evenly sprayed with steam to relax the fibers. Temperature and quantity of steam can be adjusted. The steam spraying direction can also be selected: either from the top, from the bottom or from both sides. The linear arrangement of the nozzles avoids unwanted stripes. Additional perfectly contoured spray lances can be integrated for areas that are particularly difficult to reach.

Finishing Unit

The finishing unit consists of a twinfan system and a large heating coil. The air volume and temperature are fully adjustable depending on the type of material being processed. Closing flaps at the entrance, between the processing zones and at the exit ensure a perfect finishing result.

The circulating air flow continuously impacts on the parts to be processed due to the precisely arranged location of the air duct openings. The airflow volume is fully adjustable and the air temperature is maintained at $\pm 2^{\circ}\text{C}$ of the set temperature.

Electronic Control Unit

Potentiometer, a membrane keyboard and the visual presentation through pictographs and LEDs provide for perfect electrical control. The cycles are shown to the exact second on the digital display.

The following parameters can be set:

- > Dwell time of steam and air
- > Temperature
- > Speed of airflow in the finishing unit
- > Belt speeds for continuous or indexed operation
- > Integrated resettable piece counter
- > Optional password-protected keypad
- > Optional language selection

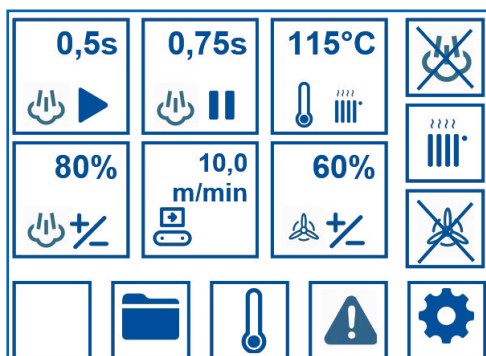
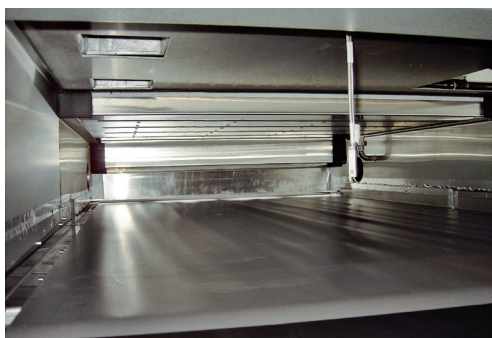

Laminating Machines



The VEIT Laminating Machine Portfolio

For every requirement the best solution

AX 450 – The fully-fledged fusing machine for prototypes and small parts



- › working width 450 mm (17.72 inch)
- › upper and lower heating zones, thermostat-controlled (**600mm - 23.62 inch**)
- › pressure system up to a maximum of 33 N/cm²
- › suitable for waistband fusing, small batches, laboratories and roll-to-roll fusing

- › Working width: 450 mm/17.72 inch
- › **NEW: pneumatic pressure system**
- › Upper and lower heating zones, thermostat-controlled (600 mm/23.62 inch long)
- › Pressure system up to 43 N/cm²
- › Ideal for in-line fusing

BH 600 – The lean-production-solution



- › working width 600 mm (23.62 inch)
- › upper and lower heating zones, individually adjustable (**length: 600 mm - 23.62 inch**)
- › ideal for dress shirt collars and cuffs
- › loading directly at the machine
- › optional stacker
- › water cooling system

BX 600/1000 – The universal solution



- › working width 600 mm or 1000 mm (23.62 inch or 39.37 inch)
- › upper and lower heating zones, individually adjustable (**length: 800mm - 31.50 inch**)
- › single or double pressure system in various degrees of hardness
- › reliable and easy to operate
- › perfectly suitable for small (600 mm - 23.62 inch) to medium-sized production plants (1000 mm - 39.37 inch)
- › gauges for electric or pneumatic failures (diagnostic system)

LM 10/LM 14 – For highest demands



- › ideal for leather, technical textiles, etc.
- › feeding belt 1400 mm (55.12 inch)
- › separate feeding and transport belts, "cool feeding"
- › special insulation, little heat radiation
- › upper and lower heating individually controlled, with temperature limiters **(1000 mm - 39.37 inch long)**
- › heating zone arrangement selectable, depending on application
- › special speed-heat up function, for fast heating of the machine
- › touch screen for program storage and service functions
- › optional air and compression cooling
- › short (800 mm - 31.50 inch) or long (1400 mm - 55.12 inch) cooling belt
- › failure diagnostic system



LM 14L/LM 16 – The most productive solution

Benefits as for LM 10/LM 14 plus:

- › extended heating zone, increased productivity **(length 1400 mm - 55.12 inch)**
- › three heating zones, more gentle heating
- › for large-scale production or centralised laminating
- › ideal for combination with feeding systems (FE-L, ET)



LAMINATING MACHINE LM

Design meets ergonomics.

Additional option

Winding and unwinding technology can be integrated mechanically and electrically

Perfectly designed service concept

allows easy and regular cleaning of machine

Accessibility

› Easy access to the wipers due to reduced machine width in the area of the cooling belt

Optimum pressure result

due to unique FLEXO pressure system achieves an optimal result with any material.

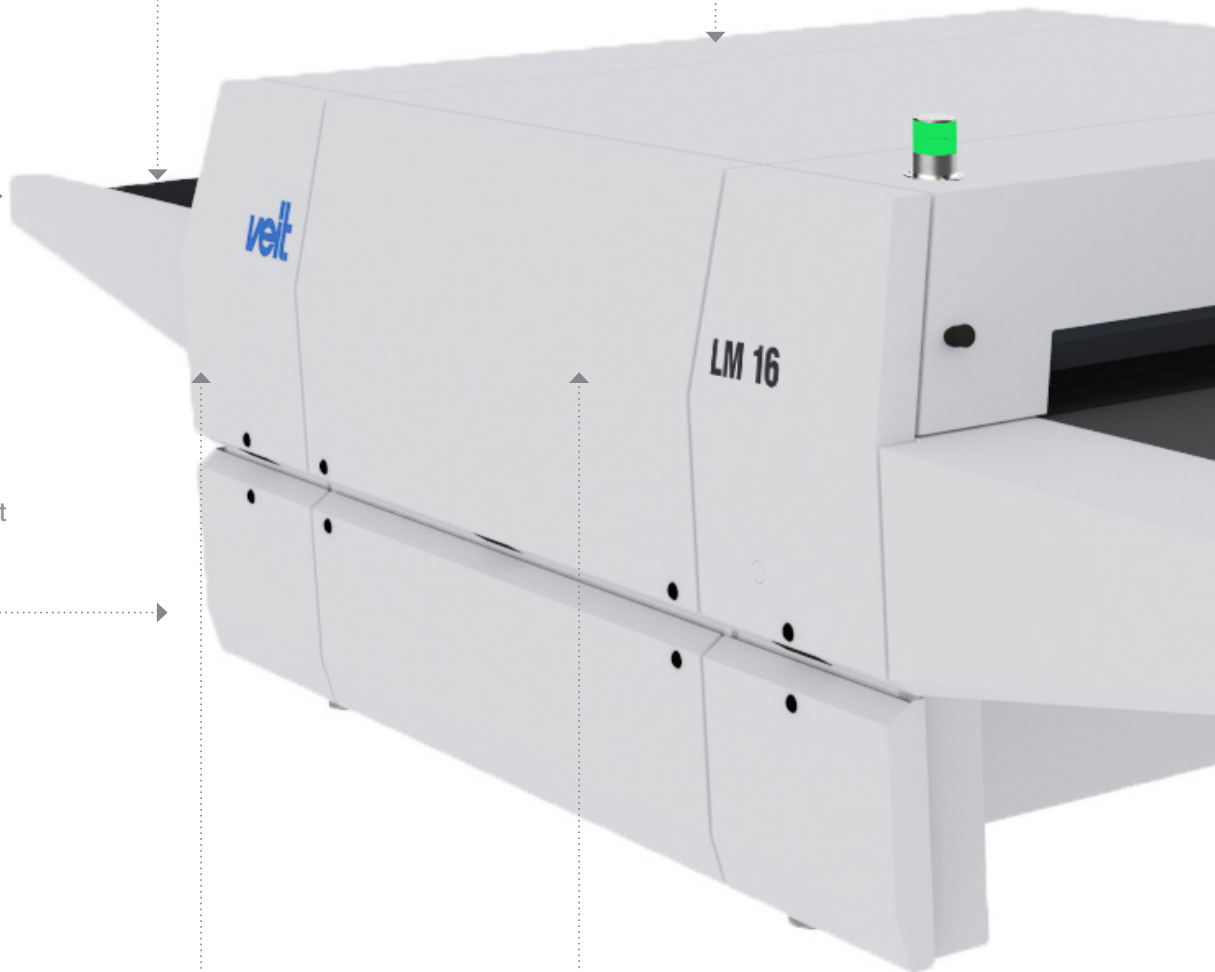

Consistent laminating quality

due to optimized cleaning of the belts both on the inner and the outer side. Consequently, major reduction in soiling of roller and laminating material

Lowest possible energy consumption
due to:

- › Separate feeding belt, no cooling of transport belt outside of machine
- › Decoupling of heating zones from machine frame
- › Enclosure of the complete machine to avoid draughts and reduce heat loss



Heating zone

even heat distribution due to two-dimensional heat transfer on each mm²

Control

- › Touch display for easier operation
- › User-optimised user interface
- › Self-diagnosis function included
- › BDE and remote service can be individually extended
- › Rotatable and tiltable display

Functionality

- › Removable FE for easy transport and installation in tight spaces
- › Start-stop function of the input conveyor in case of deviation from the set parameters as well as for easier placement of materials

Ergonomics

- › Weight savings on side panels for easier maintenance
- › Reduced basic machine height
- › Easy access to power supply

No wear and tear of belt
through contact-free belt control

Pressure systems

The Pressure System LM 10/LM 14/LM 14L/LM 16

Pressure is the crucial factor in the fusing process for achieving the desired quality and permanent adhesion.

Double Pressure System CFC – FLE XO

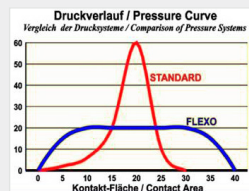
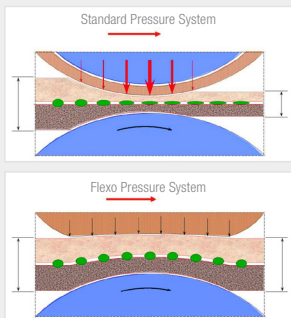
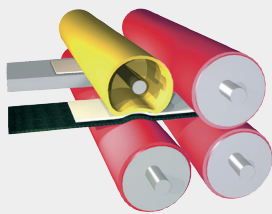

CFC - FLE XO

Developed for fusing pressure-sensitive materials, such as leather, vinyl, foil materials and others

- › The unique [FLE XO Double Pressure System](#) allows processing materials of different types and material thicknesses side by side in one work process and with the same pressure.
- › The [FLE XO roller](#) adapts to the surface and works gently and evenly due to a two-dimensional process pressure.
- › Structural surfaces (e.g. leather) and different material thicknesses are thus preserved and materials are not compressed.
- › Gentle on surfaces and materials due to lower pressure application.
- › For special purposes, the coupled standard pressure system is also available.

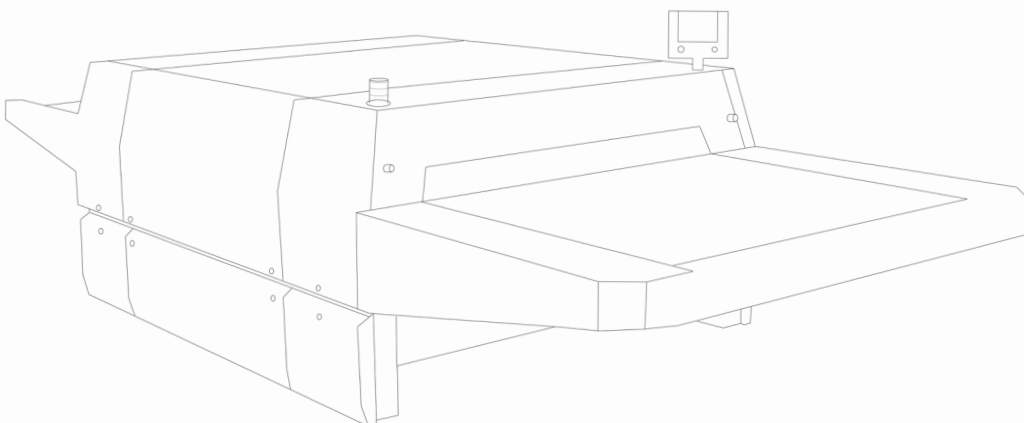

The control panel

Never before has a laminating machine been so easy to operate

Focussing on the essential and combining it with an intuitive operation – these have been our goals in designing the new 7" colour touch screen control panel.

All the relevant laminating parameters are available at a single glance on the modern, user-friendly display. In the event of a parameter digressing from the pre-set values, say

temperature is too low, the font colour turns into red and the feeding belt stops further feeding into the machine.

In addition, laminating programs can be created and saved in the control panel. They can then be copied to other LM machines via USB port.

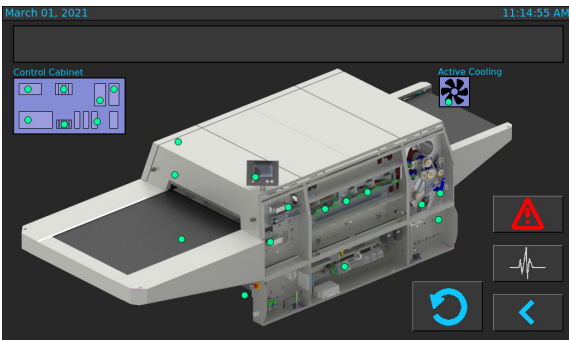

- > Language selection
- > USB port for making program copies
- > USB port for connecting an external printer
- > Diagnostic system for checking the functionality of the heating elements, the compressed air supply, the belt run and for reading out the error log

Set temperature of first heating zone

Actual value of first heating zone

Contact pressure of the first pressure system in bar or N/cm² and of the FLEXO Pressure System in bar

Belt speed in m/min and seconds

Stand-by function for energy-saving during breaks

Heating on/off

Cool-down function for cooling the belt and cleaning

Actual value of second heating zone

Set temperature of second heating zone



Contact pressure of second pressure system displayed in bar or N/cm²



LM 10



LM 16

Applications/Advantages

LM can be used for:

- > Leather
- > Textiles
- > Technical textiles
- > Foils
- > Carbon fibres
- > Filter materials
- > Industrial materials
- > Medical materials
- > Construction materials

Advantages of fusing/laminating leather and textile stampings:

- > Permanent perfectly aligned bonding of foam, felt, and fleece or knit materials to the surface material
- > The desired surface feel of the fabric can be obtained by applying different coating materials
- > The coating of leather closes the pores and prevents foam from penetrating to the other side of the material when the goods are frothed up

Laminating Machine LM

With its new **LM** laminating machine, VEIT has the ideal solution for gentle laminating of flexible materials, such as leather, and textiles cuttings of foam, felt, non-woven or knit materials. Just as well, LM can be equipped with a roll-off/roll-on device for yard goods.

The innovative VEIT FLEXO double pressure system and a flexible, spring-mounted heating zone allow precise and gentle processing of a large variety of combinations of materials and strengths in one single operation.

With these newly engineered components, we significantly reduce compression of delicate fabrics and ensure a unique laminating performance.

The innovative Contactless Belt Control (CBC) eliminates belt edge wear and tear through contact-free belt detection.

The well-conceived engineering concept of this new VEIT laminating machine is also reflected in its modern and easy-to-use touch-screen operating panel.

Not only can programs simply be fed into the system through a barcode scanner, it also allows effortless, intuitive operating for the user.

LM excels in many other ways:

- > Adjustable vertical clearance
- > Specially designed flexible spring-mounted heating zone with an adjustable heating zone radius to get the perfect settings for each material
- > Continuous roll-through: Compared to usual sliding table presses, processing times are reduced by 30 to 40 %
- > Optional production data capturing for process reliability, quality control and output evaluation
- > Upgrade to a complete production line by adding an active cooling module, a stacker and/or longer loading systems.
- > Start-Stop function for the loading belt by foot pedal, to allow alternating between continuous and cyclic operation
- > Optional automatic cleaning function of the upper transport and cover belt to remove glue residue
- > Optimized insulation to minimize energy loss and operator impairment through heat radiation
- > The LM is available in the following versions:
 - > LM 10 (working width 1000 mm)
 - > LM 14 (working width 1400 mm)
 - > LM 14 L (working width 1400 mm, extended heating zone)
 - > LM 16 (working width 1600 mm)

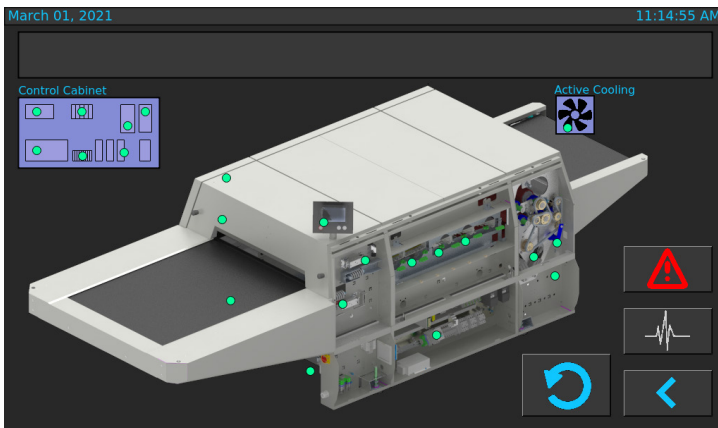
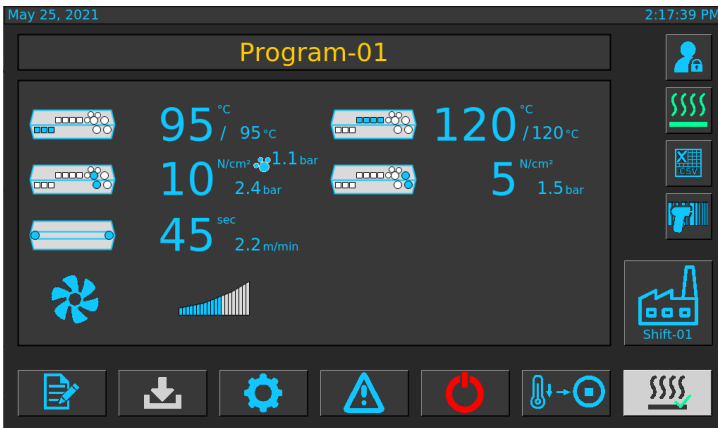

Laminating Machine LM

Touchscreen

The touchscreen control allows the adjustment and control of all necessary parameters:

- > Indication of set/actual temperature of the different heating zones
- > Parallel display of laminating time (sec) and speed (m/min)
- > Parallel display of pressure in bars and N/cm²
- > Fill level indicator for optional stacking device
- > Self-diagnosis system with immediate error message (visual and acoustic)
- > Visual machine availability via signal lamp green/red
- > Storing of different programs which can be run when required (optionally with production data acquisition (= PDA))
- > You can save up to 200 programmes.
- > Identification of laminating item via hand-held scanner is possible (as an option)
- > Excellent lamination: patented heating technology, reliable and energy-saving, has high reserves to quickly compensate for temperature drops

Heat zone 2/3 bottom/top

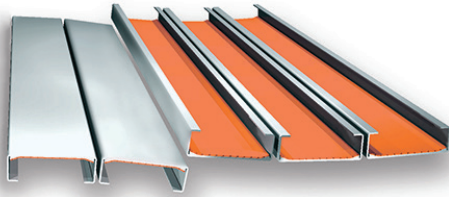

Heat zone 3/2 bottom/top

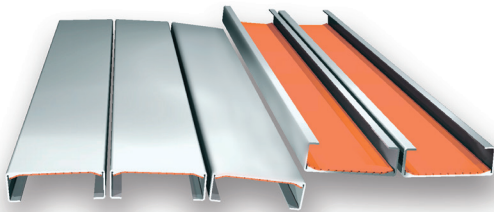

Heat zone 3/4 bottom/top

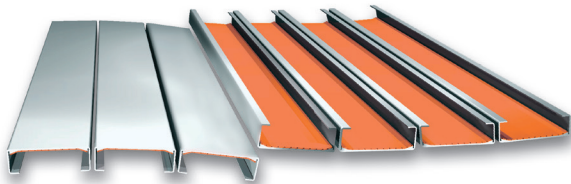

Heat zone 4/3 bottom/top

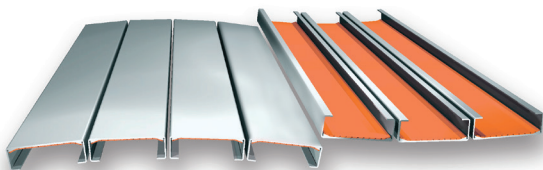

Heat zone 3/4 top/bottom

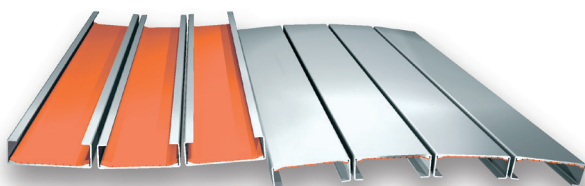

Laminating Maschine LM

Heating Systems

Variable temperature settings at the bottom and the top layer of the materials to be fused are essential in order to achieve the desired adhesion.

For a perfect result for a multitude of differing requirements and materials, **LM** offers the possibility of choosing from a variety of heating zone arrangements, to ensure the desired temperature at the joint.

VEIT's proven heating system with the following advantages:

- › A patented heating element which transfers the temperature evenly over the entire surface without any significant loss of heat
- › Arched heating zones to guarantee an optimal inner heat transfer from the heating element via the conveyor belt to the material being fused
- › Two heating zones, where temperature can be adjusted separately – for perfect results
- › The arrangement of the heating zones can be changed at any time when needed
- › No large gap between the individual heating elements. This prevents any cooling down of the glue in the heating area and avoids hard handle and low bonding
- › Temperature control which guarantees uniformity between set and actual temperature. This is done through a sensor that is located directly on the heating mat
- › Permanent adjustment of actual to set temperature
- › Spring-loaded lower heat zone for processing pressure-sensitive materials
- › Adjustable vertical clearance at the inlet as well as in the heat zone

Options for LM

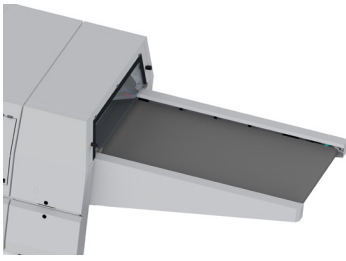

The recirculating air cooling station with the overall length of 1700 mm and 3000 mm can be equipped with additional fan rows (optionally with one up to four additional fan rows).

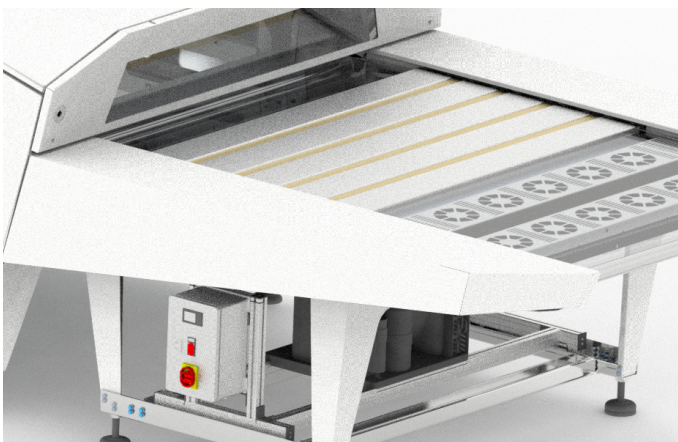

Air Fan Cooling Station LM

Principle

The **air fan cooling station** ensures that the fused composites are sufficiently cooled to avoid any deformation or loosening of the bonding after the laminating process. Also, it prevents marks on the surface of sensitive materials in the event of any premature manual unloading.

The **air fan cooling station** is available with up to four rows of fans, depending on the requirements and the length of the cooling station.

Feeding System FE-L

Customers benefit from the advantages of the flexible workplace organisation FE-L

The extended loading system is 3000 mm long and allows better use of **LM** capacity. Using the extended working area, up to eight operators can load the fusing machine. Due to a synchronised speed of loading and transport belt, distortion is totally eliminated.

The belt speed can be controlled manually with a potentiometer. When connected to **LM**, belt speed is controlled automatically. FE-L can be optionally equipped with a maximum of four loading tables (width: 230mm / 370 mm), providing more space for preparing adhesives and composite materials.

Main advantages

- › Up to eight operators can simultaneously load the fusing machine
- › Efficient utilisation of your fusing machine
- › The feeding belt can easily be switched on or off by pressing a foot switch. This will avoid problems caused by displacement of interlinings with fabrics which are difficult to load.
- › Working widths available: 1000 mm / 1400 mm / 1600 mm

Active Cooling Module AKM

Principle

The **Active Cooling Module AKM** cools the fused composites of different materials after processing to avoid deformation or loosening of the bonding which may happen in case of insufficient cooling of the adhesive. It also prevents marks on the surface of sensitive materials in the event of premature manual unloading. The cooling temperature is entirely variable, depending on the processing temperature within **LM**.

Technology

The **Active Cooling Unit** with a closed water cooling cycle system and an air fan system can be chosen when working with high temperatures in order to achieve fast cooling. The amount of air and the cooling power can be steplessly regulated via the separate control unit. The **Active Cooling Module** is directly linked to the **LM**, so that no extra connections are required.

AX 450 / AX 450 C



Despite its minimized dimensions, the **AX 450** offers the same attributes as the larger models. It can be utilized for fusing waistbands as well as full-fledged fusing of sportswear and dress shirts.

Advantages:

- > Full-fledged fusing for small production runs, labs or assembly lines
- > Requires no compressed air
- > Single phase electrical connection
- > Rolling stand design
- > Partial fusing capabilities



The Control Unit:

Even our compact fusing machine comes equipped with a full-fledged control unit.

Advantages:

- > Unique in its class, a diagnostic system for heating elements, motor control and belt control
- > Clear, simple color display for under or over heating
- > Calibrated thermostat, necessary for belt exchange or different belt types
- > Set/actual temperature monitoring

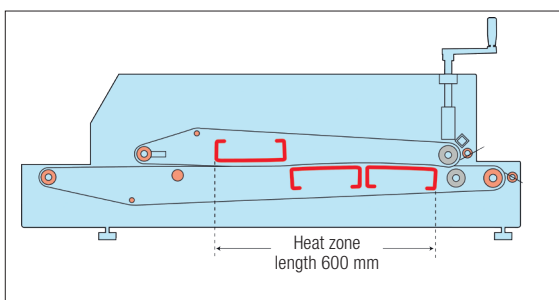

Heating System
 Pressure System

The Heating System:

The heat technology and heat zone configurations are incorporated from our larger fusing machines, guaranteeing maximum quality.

Advantages:

- > Separate upper and lower heat zones
- > Proven VEIT surface heat technology with uniform surface distribution
- > Minimal energy usage, with each outlet serviced by 16 amp fuse
- > Panel heating elements provide specific heat transfer with minimal energy waste

AX 450 / AX 450 C

The mechanical Pressure System:

The **AX 450** has a sophisticated mechanical pressure system which operates without compressed air and yet delivers precise pressure. Pressure specifications are shown in N/cm^2 , as requested by leading interfacing suppliers.

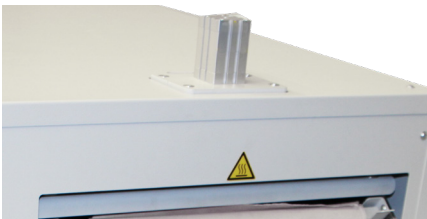
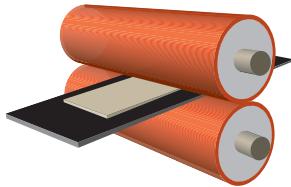

The pneumatic Pressure System

With the trend towards increasing individualisation, producing **small numbers** is becoming increasingly important **in shirt production**. Customised production of tailor-made shirts, too, results in a need for flexible production lines. With this fully-fl edged fusing machine, VEIT FUSING provides the possibility of decentralised fusing directly in the production line without any cut-backs in quality.

Options:

Unloading Slide

Accommodates large and small fused assemblies for cooling.

Waistband Fusing Device

Various options are available for mechanical unwinding and rewinding for waistband fusing. The waistband fusing device may be operated individually or by two people. We further recommend a loading guide for accurate positioning of the face fabric and the interlining.

Mechanized Rewinding "Stretch"

We offer an electronically driven option for rewinding fused waistbands of elastic fabrics, eliminating stretch.



BX 600/1000 Series

The compact solution!

Designed for daily use in outerwear or dress shirt productions.



Advantages:

- > Sturdy, compact design requires minimal floor space
- > Extended heat chamber
- > Rapid machine warm-up
- > Totally reliable and adjustable/maintains accurate temperature and pressure

The Control Unit:

Control of the fusing parameters is of utmost importance in a fusing machine, where all important details can be overseen in a clear and readable manner. Fluctuations in temperature are highlighted to draw quick attention.

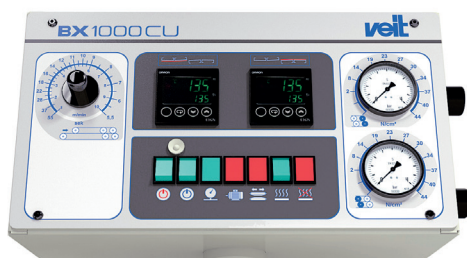

Advantages:

- > Separately controlled and adjusted upper and lower heat zones, individually adjustable for various fabric and interlining combinations
- > Clear, simple color display with temperature control to prevent too low or too high temperatures
- > Diagnostic system for belt progression, electrical supply and compressed air supply

The Heating System:

As with all continuous VEIT fusing machines, our special heating elements play an important role. Clearly defined heat zones provide for optimal fusing results.

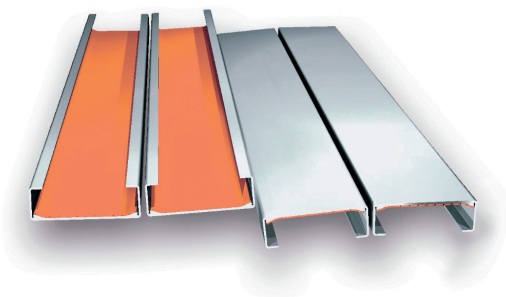

Advantages:

- > Uniform surface temperature due to curved heat zone
- > No gaps between heating elements, facilitating uniform heat distribution
- > Rapid temperature change
- > Specially insulated heating elements for minimal energy waste

The Pressure System:

The precise pressure for successful fusing of different interlinings and fabrics varies; therefore, a pressure system must be able to address these needs. The BX is the only fusing machine in its class offering a choice of two standard pressure systems to best meet the needs of our clients.

BX 600/1000 S (soft)

Applicable for pressure sensitive fabrics used in sportswear and especially in women's and men's apparel

BX 600/1000 M (medium)

Applicable for common fusing applications in goods with high-twist yarns and dress shirt industry

Advantages:

- > Roller combinations can be chosen between soft and medium
- > Fast exchange of pressure rollers possible at any time

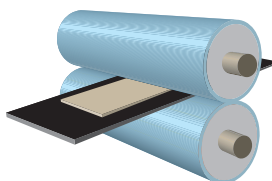

C S (soft)

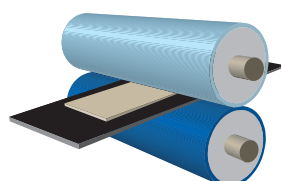

C M (medium)

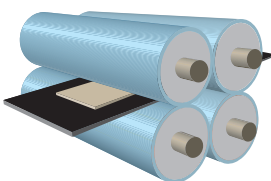

CU S (soft)

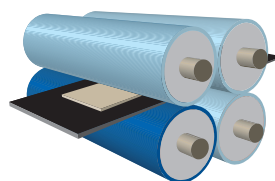

CU M (medium)

Options for the LM and BX Series

Return-to-Operator System (for BX)

A return-to-operator system is especially beneficial for smaller production runs, allowing a single operator to both load and unload the machine.

Advantages:

- > Low space requirement
- > Increased productivity and efficiency

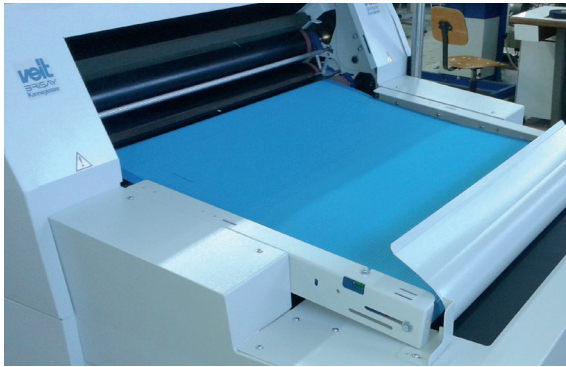

Waistband Fusing Device (for LM and BX)

Continuous roll to roll fusing is possible for trouser and skirt waistbands.

Advantages:

- > All waistbands for one particular product are on one roll, maintaining product integrity
- > Fusing occurs according to a continuous sequence



Rotating Strip-Off Device (for LM)

Through rotation of strip-off device along the upper belt, pieces adhering to the belt are gently and effectively removed.

Advantages:

- > Gentle removal of pieces from the upper belt with rubber ridges
- > Unique design allows damaged ridges to be replaced individually without removal of the entire strip-off device, facilitating rapid and cost effective repair
- > Low maintenance



Lateral Loading Tables (for LM)

For preparation of oversized pieces, the fusing machine can be equipped with lateral loading tables.





Loading Systems for LM and BX

A loading system may be incorporated for even more efficient use of the fusing machine.

FE-L Loading System

The **VEIT FE-L** is an extended version of the FE loading belts in the LM and BX series. The **FE-L** can either be added to extend the standard FE loading belts or can be installed instead of the standard FE loading belts. An extended loading zone allows for additional operators.

Advantages:

- › Foot switch can be used to start and stop the belt
- › Oversized pieces can be processed
- › Additional operators can be utilized for loading
- › FE-L can be installed on the LM
- › As an additional installation – 4400 mm (176 inch)
- › As the primary installation – 3000 mm (120 inch)



VEIT Stacker

It is important that fused assemblies be handled gently to allow them to cool prior to further processing.

The **VEIT Stacker** guides the fused assemblies from the loading system's cooling belt of the BX or LM series to the unloading table. At this point the unloading table is activated by a sensor and moves under the piece until the entire length is transferred. Thereafter, the unloading table returns to its position under the belt to receive the next piece. This system is available for working widths 1000, 1400 and 1600, from two to four separate operating trays.

Advantages:

- › Automatic stacking of fused assemblies
- › Choice of various belt widths
- › Coupling of stacker lanes for extra wide pieces
- › Flat transfer of fused assemblies
- › Pieces placed in order
- › Pieces placed for precise bundling



BH 600 – Shirt Fusing Machine

Specifically designed for fusing dress shirt collars and cuffs, this machine is equipped with an active cooling system and is operated by one person. When equipped with the **BH ST 600 Stacker**, an optical sensor causes all fused assemblies to be collected automatically.

Advantages:

- > Can be operated by one person
- > Proven VEIT panel heating technology
- > Active Cooling System for fused assemblies
- > Optional stacker available for higher productivity

The Control Unit:

Reliability in terms of fusing parameters is essential for the fusing operation. A clear display of those parameters on the fusing machine is important for the operator to maintain an even quality.

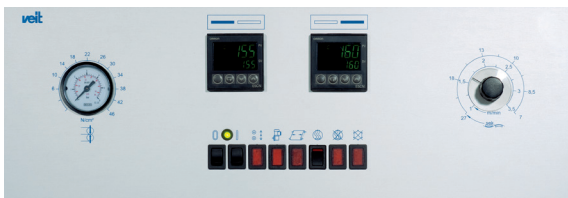

Advantages:

- > Clear display of fusing parameters
- > Clearly visible by operator
- > Diagnostic system for heating elements, motor control and belt progression
- > Clear, simple color display with temperature control to prevent too low or too high temperatures
- > Set/actual temperature monitoring
- > Control indicators for active cooling system

The Heating System:

As with all VEIT fusing machines, the **BH 600** is equipped with our proven panel heating technology.

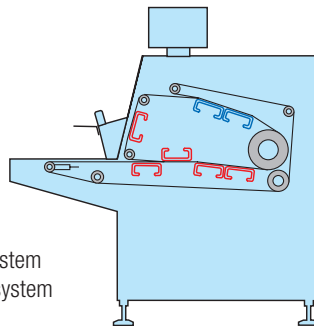

heating system
 pressure system

Advantages:

- > Exact and separate temperature adjustments for upper and lower heating zones
- > Uniform surface heat distribution over the entire fusing width
- > Panel heating elements provide specific heat transfer with minimal energy waste

The Pressure System:

The pressure system for fusing dress shirts is very important, because most adhesive resins for shirts require high pressure. With the **BH 600**, the fused assembly is held under additional contact pressure after proceeding through the initial pressure system.

Advantages:

- > Pressure adjustable from 0 N/cm² to 46 N/cm²
- > Large return drum delivers contact pressure, ensuring success full adhesion

Options:

BH ST 600 Stacker

Can be retrofitted or factory installed. This stacker straightens and stacks fused assemblies.

Advantages:

- > Higher productivity
- > Collars and cuffs stacked for precise bundling
- > Suitable for Lean Production Lines



Technical Data

Model	Page	Connections					Working Pressure (adjustable)	Voltage
		Steam	Water	Condensate	Waste Water	Exhaust Steam		
VEIT SG 67 2.2 kW	3	3/8"	optional	–	–	–	3.5–5.0	230/50–60*2.2
VEIT SG 67 4.4 kW	3	2 × 3/8"	optional	–	–	–	3.5–5.0	400/50–60*4.4
VEIT SG 67 6.6 kW	3	2 × 3/8"	optional	–	–	–	3.5–5.0	400/50–60*6.6
VEIT 2381 40 kW	3	3/4"	3/8"	1/2"	3/4"	1 1/4"	6 (7)	400/50/40
VEIT 2381 50 kW	3	3/4"	3/8"	1/2"	3/4"	1 1/4"	6 (7)	400/50/50
VEIT 2381 60 kW	3	3/4"	3/8"	1/2"	3/4"	1 1/4"	6 (7)	400/50/60
VEIT IF 60/1000	4–5	2 x 1/2"	–	1/2"	–	–	6	400/50/4
VEIT IF 60/1600	4–5	2 x 1/2"	–	1/2"	–	–	6	400/50/4

Model	Dimensions				
	W × D × H in mm (inches)	Weight in kg (lbs)	Steam output in kg/h (lbs/h)	Steam user	Options
VEIT SG 67 2.2 kW	305 × 652 × 812 (12 × 25.7 × 31.9)	40 (88)	3	1 iron	
VEIT SG 67 4.4 kW	305 × 652 × 812 (12 × 25.7 × 31.9)	40 (88)	6	2 irons	with solenoid valve and ball valve (e. g. for Detaset)
VEIT SG 67 6.6 kW	305 × 652 × 812 (12 × 25.7 × 31.9)	40 (88)	9	2 irons	
VEIT 2381 40 kW	1080 × 780 × 970 (42.5 × 30.7 × 38.2)	340 (750)	55	Irons/Topper/ Finisher/Up-Steam table/small pressing machines	Connection and elevation set
VEIT 2381 50 kW	1080 × 780 × 970 (42.5 × 30.7 × 38.2)	340 (750)	68	Irons/Topper/ Finisher/Up-Steam table/small pressing machines	Connection an elevation set
VEIT 2381 60 kW	1080 × 780 × 970 (42.5 × 30.7 × 38.2)	340 (750)	78	Irons/Topper/ Finisher/Up-Steam table/small pressing machines	Connection an elevation set
VEIT IF 60/1000	1845 × 4466 × 1960 (72.64 × 175.83 × 77.17)	1300 (2866)	120	–	
VEIT IF 60/1600	2463 × 4466 × 1960 (96.97 × 175.83 × 77.17)	1600 (3527)	160	–	

* Special voltage upon request. Subject to alterations. All specifications have been made to the best of our knowledge.

Technical Data

Model	LM - Continuous Laminating Maschine						
	Fusing Width in mm (inch)	Belt Speed in m/min (ft/min)	Air Pressure Ø=8 mm	Voltage in Volt/Hz/kW	Dimensions: W × D × H in mm (inch)	Weight in kg (lb)	Air Consumption in l/min.
LM 10 CFL	1000 (40)	1.0–10,0 (3.3–33)	6.5	3 × 400/50–60/23	1650 × 5650 × 1510 (65 × 222 × 60)	1200 (2646)	50
LM 14 CFL	1400 (55.11)	1.0–10,0 (3.3–33)	6.5	3 × 400/50–60/29,5	2050 × 5650 × 1510 (81 × 222 × 60)	1430 (3153)	50
LM 14L CFL	1400 (55.11)	1.0–10,0 (3.3–33)	6.5	3 × 400/50–60/42	2050 × 6050 × 1510 (81 × 238 × 60)	1500 (3307)	50
LM 16 CFL	1600 (63)	1.0–10,0 (3.3–33)	6.5	3 × 400/50–60/48	2250 × 6050 × 1510 (89 × 238 × 60)	1600 (3527)	50
AX 450 AX 450 C	450 (18)	1.6–10	mechanical pneumatical	1 × 230/50–60/3.6	2050 ³⁾ × 930 ³⁾ × 604/1302 ⁴⁾	330/370 (728/816) ¹⁾	–
BX 600 C BX 600 CU	600 (24)	1.7–10	6.5	3 × 400/50–60/10.8	2900 × 1150 × 1500	520 (1144)	< 1
BX 1000 C BX 1000 CU	1000 (40)	1.7–10	6.5	3 × 400/50–60/17.5	3600 × 1580 × 1500	670 (1474)	< 1
BH 600	600 (24)	1.0–2.5	6.5	3 × 400/50–60/12,5	1560 × 1060 × 1550	470 (1036)	< 1

Pressure Values for Fusing machines		
Modell und pressure system	pressure in bar	pressure in N/cm ²
AX 450	mechanical	0–33 N/cm ²
AX 450 C	pneumatical	0–43 N/cm ²
BH 600	1–6	6–46 N/cm ²
BX 600 Soft	1–6	2–44 N/cm ²
BX 600 Medium	1–6	4–49 N/cm ²
BX 1000 Soft	1–6	2–44 N/cm ²
BX 1000 Medium	1–6	4–49 N/cm ²

Model	Options for LM - Continuous Laminating Maschine						
	Working Width in mm (inch)	Loading Length in mm (inch)	Air Pressure Ø=8 mm	Voltage in Volt/Hz/kW	Dimensions: W × D × H in mm (inch)	Weight in kg (lb)	Air Consumption in l/min.
FE-L 10	950 (38)	3000 (120)	–	1 × 230/50–60/0.55	1110 × 3130 × 850–950 (44 × 123 × 33–37)	250 (550)	–
FE-L 14	1400 (56)	2830 (111)	–	1 × 230/50–60/0.55	1850 × 3300 × 850–950 (73 × 130 × 33–37)	300 (661)	–
FE-L 16	1600 (64)	2830 (111)	–	1 × 230/50–60/0.55	2050 × 3300 × 850–950 (81 × 130 × 33–37)	390 (860)	–

* Special voltage upon request. Subject to alterations. All specifications have been made to the best of our knowledge.

The VEIT Group



Pressing for Excellence – Why you can rely on the VEIT Group

The VEIT Group is based in Landsberg am Lech (Germany) and is the leading manufacturer worldwide for machines and plants in the field of ironing, fusing, pressing and refinishing of garments. Our product portfolio ranges from traditional ironing tables and presses to fusing machines and also includes automated units.

VEIT Group: the story of our success

- 1956 Foundation of VEIT Group with now 14 companies in 12 countries worldwide
- 1989 Purchase of BRISAY, Aschaffenburg, with a portfolio of cutting-edge ironing machines
- 2001 Acquisition of Kannegiesser GTT in Vlotho with their internationally renowned fusing machines and shirt ironing machines
- 2003 Production and further development of Kannegiesser products through VEIT
- as of 2014 Distribution of Kannegiesser products exclusively under the VEIT brand name

Quality

For over 60 years, our customers' requirements and challenges have been our driving force to press for excellence. For decades, world famous brands in the German and international garment industry have placed confidence in the innovative, high quality products and services offered by the VEIT Group.

Efficiency

Our experts consult and partner with you in finding the best possible solution for your project needs, whether you require individual machines or a complete product line.

Service

Prompt delivery and professional installation of our machines and systems go hand in hand with premium training, through which we equip your staff with the skills necessary to achieve the highest possible production. Our service technicians are always available, around the world and around the clock, maximizing continuous production.



VEIT GmbH

Justus-von-Liebig-Str. 15
 86899 Landsberg/Lech
 Germany
 Tel. +49 (8191) 479-100
 Fax +49 (8191) 479-149
 E-Mail: info@veit.de
www.veit-group.com

Your local sales agent:

